

MODEL YAMAHA FZS 1000 FAZER

YEAR 2001-2005

LINE SPORT

MUFFLER GP

SCHEMATIC
ELENCO PARTI / PARTS LIST

#	QTÀ / QTY	DESCRIZIONE / DESCRIPTION	CODICE / CODE
1	1	DB killer / DB killer	50.DK.020.0
2	1	Silenziatore / Muffler	GP
3	1	Protezione in gomma per staffa / Rubber protection for bracket	50.73.040.1
4	1	Staffa / Bracket	50.SS.001.0
5	1	Dado 8 MA flangiato / Flanged nut 8 MA	50.73.052.1
6	1	Distanziale in alluminio / Aluminium spacer	50.SS.055.1
7	1	Rondella in alluminio / Aluminium washer	50.73.063.1
8	1	Vite M8x80 / Screw M8x80	50.73.072.1
9	1	Tubo di raccordo / Link pipe	9773Y009S2
10	1	Fascetta Ø 60/63 mm / Pipe clamp Ø 60/63 mm	50.FA.010.1
11	1	Molla / Spring	50.71.080.1
12	1	Tubo in gomma per molla / Rubber pipe for spring	50.73.210.1

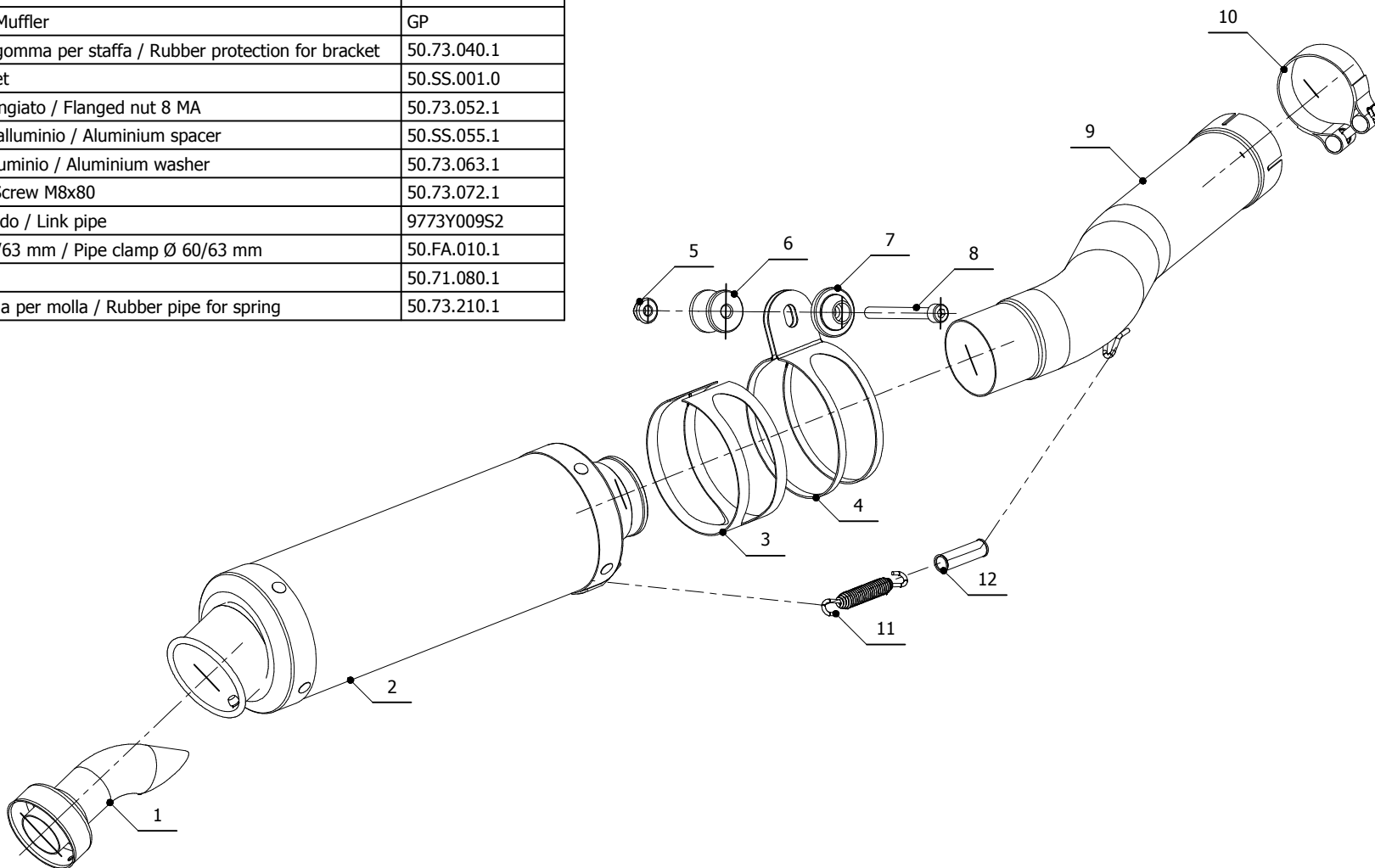
APPLICAZIONI / APPLICATIONS

CODICE / CODE	TUBO / PIPE	SILENZIATORE / MUFFLER	FASCETTA / CLAMP	CODICE OMOL. / HOMOL. CODE
Y.009.L2S	INOX / ST. STEEL	CARBONIO / CARBON FIBER	INOX / ST. STEEL	ME008 e9 1176
Y.009.L6S	INOX / ST. STEEL	TITANIO / TITANIUM	INOX / ST. STEEL	ME008 e9 1176